



Duranta

1,675 Square Feet

Community: Alberta Heights

LOW VOLTAGE LEGEND	LOGO	DESCRIPTION
		COAXIAL CABLE
		DATA
		ISP JUNCTION

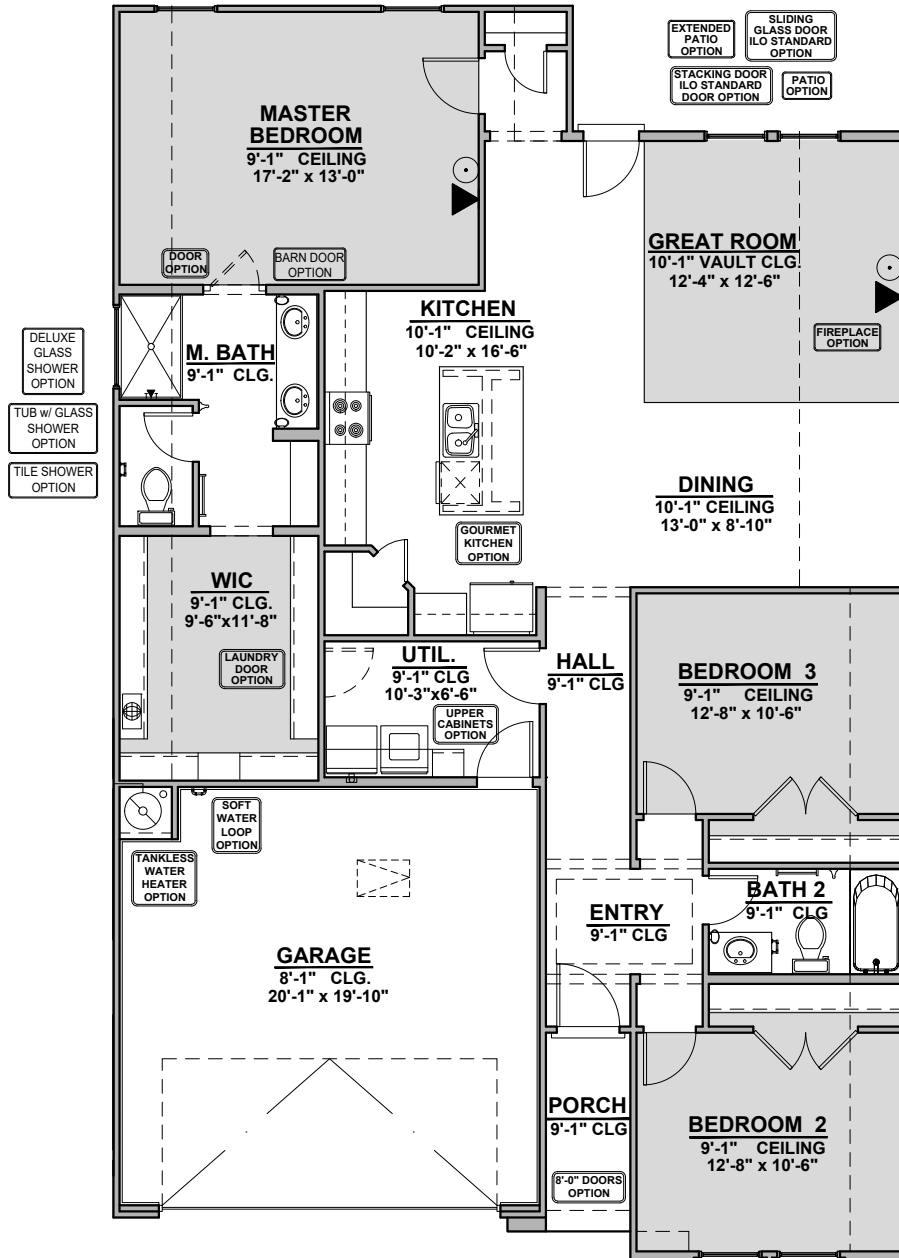

Home is complete and accepted as built. _____

Home construction is in process, buyer accepts all option locations. _____



Duranta Elevations

1,675 Square Feet

Community: Alberta Heights

LOW VOLTAGE LEGEND	
LOGO	DESCRIPTION
	COAXIAL CABLE
	DATA
	ISP JUNCTION

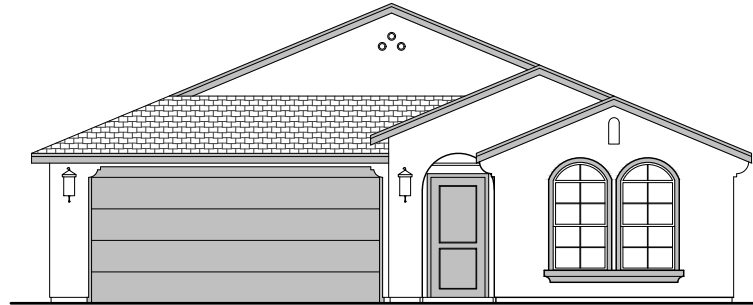

Spanish Colonial (A)



Tuscan (B)



Farmhouse (I)



Craftsman (F)



Duranta Options

1,675 Square Feet
Community: Alberta Heights

LOW VOLTAGE LEGEND	
LOGO	DESCRIPTION
	COAXIAL CABLE
	DATA
	ISP JUNCTION

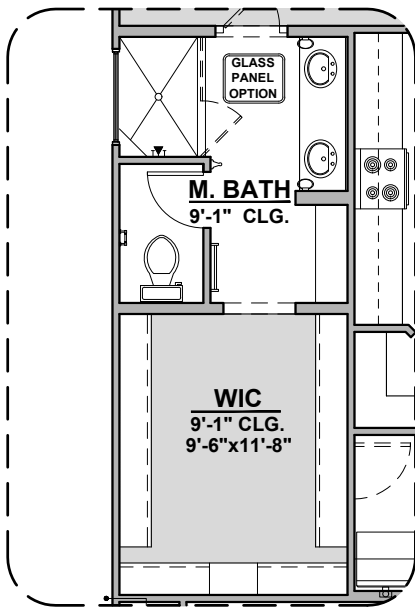

TILE SHOWER OPTION
1/4" = 1'-0"

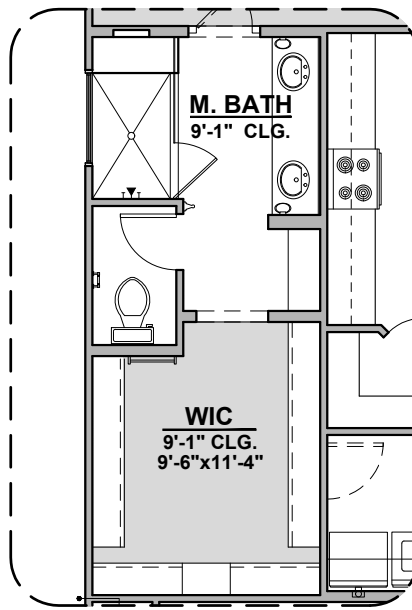

DELUXE GLASS SHOWER OPTION
1/4" = 1'-0"

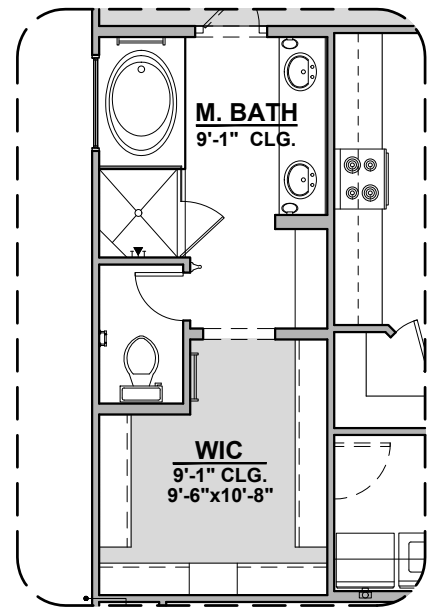

TUB w/ GLASS SHOWER OPTION
1/4" = 1'-0"

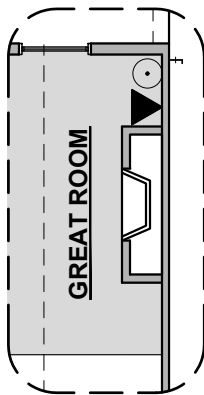

Fireplace

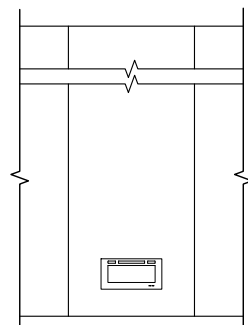

Contemporary
Fireplace

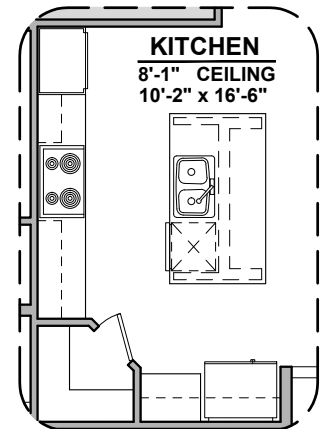

Gourmet Kitchen



Duranta Options

1,675 Square Feet
Community: Alberta Heights

LOW VOLTAGE LEGEND	
LOGO	DESCRIPTION
	COAXIAL CABLE
	DATA
	ISP JUNCTION

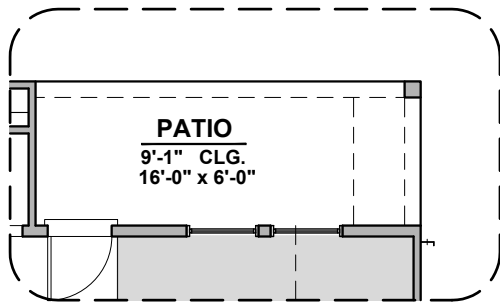

Patio

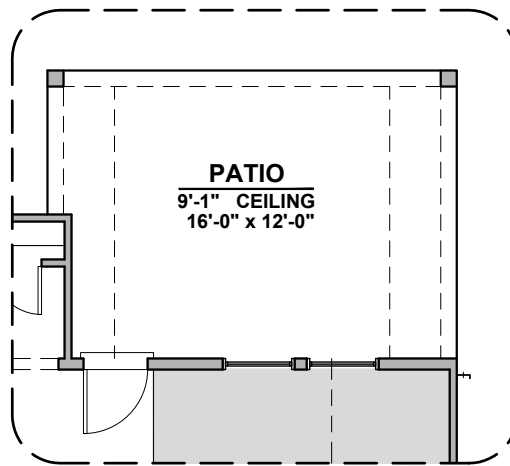

Extended Patio

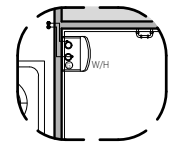

Tankless W/H

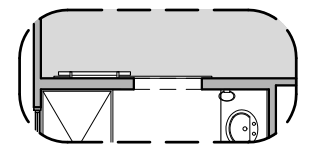

Barn Door

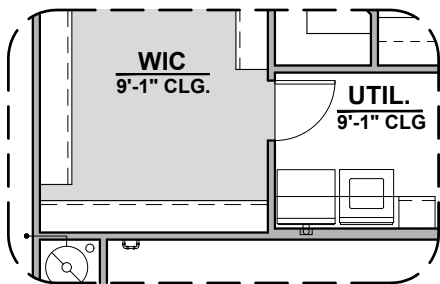

Laundry Door

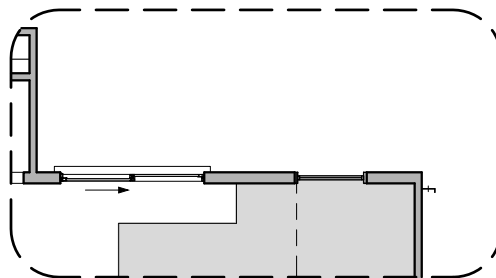

Sliding Glass Door
ILO STD. Door

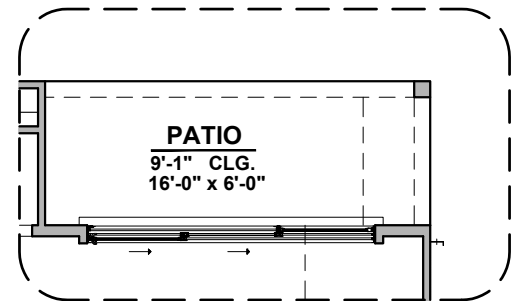

Stacking Door ILO STD. Door

*Note: All vinyl in Great Room with this option